

CENTRE FOR JOINT WARFARE STUDIES



EXPLOITING SPECIAL OPERATION FORCES-BEYOND THE SURGICAL STRIKES

SYNODOS PAPER

VOL - XI NO 7 / OCT 2017

When India conducted surgical strikes, the world experienced our power and realised that India practices restraint but can show power when needed,”

**PM Modi
at Washington- 26 June 2017**

When we play Maggie Plays” was displayed prominently on a billboard at the gates of the British Special Air Section (SAS) Training Centre at Credenhill, Herefordshire, UK, on return from the Falkland war. The SAS are the proverbial mother of all Special Forces raised by ‘Phantom Major’ David Stirling during the second world war. The message was clear that when the British SAS operates it is to either project or protect national interests and to hence the decision making is at the highest levels. The Special Operation Forces (SOF) in India have mainly been employed at the tactical level

except for Operation Cactus (Maldives) wherein 50 (I) Parachute Brigade/6 Battalion the Parachute (PARA) Regiment spearheaded and successfully executed a military intervention operation in Nov 1988 to rescue the then President of Maldives from a coup and restore the duly elected Government of President Gayoom. The only other occasion of a Special Operation contributing directly to a national aim or a cause was the Airborne drop/assault by 2 PARA in 1971 War at Tangail, which was directly instrumental in the early capture of Dhaka and Liberation of Bangladesh. It is only now that PM Modi has realised and exploited the full potential of the SOF / Para SF in executing the ‘Surgical Strikes’ first against the NSCN(K) on 09 Jun 2015 in Myanmar, post the ambush on 6 Dogras in Chandel and more importantly in Pakistan Occupied Kashmir (POK) on 28/29 Sep

2016 against terrorist launch pads after the terrorist attacks on the Uri military base. The impact of the Surgical Strikes was at the strategic domain and hence a direct concern at the apex political levels – the PM. The Indian PARA SF have played a pivotal role in shaping national strategy, raising the costs for Pakistan in its state policy of waging a ‘low cost high effect war’ on India.

Historically the SF have been employed at the tactical level, be it the 1971 War , Op Pawan (Sri Lanka), Op Vijay (Kargil) and Counter Terrorism (CT)/ Counter Insurgency (CI) Operations in J&K and NE. The Para & Para SF Units have undoubtedly excelled as evidenced by the number of COAS unit citations and gallantry awards. This has helped the SOF to hone their skills and acquire the much needed and critical combat experience. Despite a proven record of success over the years albeit mostly at the tactical level in CI/CT operational scenario, the SOF have been hampered by unimaginative employment, lack of optimal structures, access to national decision making and an ever growing hollowness in capabilities and capacities on account of voids in requisite arms and equipment. Now that the Para SF has been employed in the strategic domain, executing surgical strikes against Pakistan, hopefully the government will wake up from their slumber and provision the long awaited wherewithal.

As India now grows to be a risen, responsible regional power and a net

security provider in the region it will need the SOF to project and protect its national security interest and assets. While addressing the Indian community at Washington during his recent visit PM Modi drew the loudest response when he spoke on the surgical strikes conducted after the Uri attack last September. Surgical strikes triggered the imagination and interest of all Indians, instilling a sense of pride in the nation state as it responded to Pakistan sponsored terror attacks. This was made possible by a select band of soldiers who pride themselves at being the best in the business in the world. The PARA (SF) are by far the most battle hardened and combat rich force in the world on account of their constant and continuous deployment in CT and CI operations in J&K and North East. The PARA and PARA (SF) personnel of the Indian Army are all volunteers drawn from the 1.2 million strong volunteer army, the very best opt to serve in these units and with a selection percentage of a little under 20%, those selected make dream combatants , capable of delivering under the toughest , most challenging and dangerous situations. Success and mission accomplishment comes naturally to them. They are different, in fact they are a ***“bunch of misfits who fit well together”***.

The surgical strikes executed on the night of 28/29 Sep 2017 were and are unprecedented. The selection of the targets was very apt – seven terrorist launch pads across the Line of control (LC) in Pakistan Occupied Kashmir (POK) within a few kilometers of the LC, located on either side

of Pir Panjal nearly 350 Kms apart. Seven troops comprising of 140 odd PARA (SF) Commandos, one target per troop inserted on foot on a zero moon night, totally undetected in a heavily manned and mined LC, destroyed the designated targets by fire assault from close ranges, without any collateral damage to civilian population in POK and thereafter executed the most difficult part of the operation (having lost surprise) extrication to own side without a single casualty. For anyone who has served along the LC – the enormity of the task itself would have sent shudders. The LC is not only heavily manned and mined, the Pakistani troops deployed are trigger happy despite a prevalent cease fire. Surgical strikes are a very sensitive and delicate operation with no room for error. Firstly, all those who executed knew well that it was a 'One way ticket'. Secondly, any soldier having been left behind would have been a national embarrassment, he would have been paraded as a Pakistan victory and an Indian Military failure. In numbers it achieved little, as per some reports only 39 terrorists were killed, of course Pakistan denied any such action. The strikes at the terrorist launch pads is a master stroke by the Nation and the Army where in a single operation they have executed both 'Punitive' operations avenging the martyrdom of the 19 soldiers of the Uri attacks, and 'pre-emptive' operations, by destroying the terrorists and their launch pads. The strategic signalling has left no doubts that India will respond militarily to cross border terrorism, as reiterated by the Army Chief General VVIP Rawat.

The key question however remains to be answered - Is India as a nation and the Armed Forces fully exploiting the potential of our SOF? Are they optimally structured and equipped? A clear and concise answer is NO. There are major causative factors which need to be addressed.

There is a plethora of SF in the Indian security context. Without debating on the quality and requirement of the over two dozen self styled and self proclaimed SF ranging from the State Police and the CAPF, the focus of this paper will remain on the SOF of the Armed Forces. India boasts of the second largest Army, the fourth largest Air Force and a blue water capability for the Navy to ensure our territorial integrity against external threats and internal security. What the nation lacks is a credible rapid deployment and effective Special Operations capability, to meet emerging security challenges in the regional and global context. The three services have their integral SOF. These are service specific and more often than not, there is competition and conflict of interests, rather than cooperation and coordination, be it their roles and tasks, equipping, training and command and control. The poor military response to the Pathankot terror attack is indicative of the conflict of interests. Existing SOF of the Armed forces include nine Parachute (Special Forces) Battalions, five Parachute Battalions of the Army, the Parachute Brigade, an 800 strong Marine Commando Force (MARCOS) organised on the concept of the US Marines and a 1000 strong IAF

Garuds, likely to grow to 10,000 to ensure security of Air Force bases (post Pathankot), as per some media reports. The NSG and the Special Group manned and led by the Army for internal security and hostage rescue are under the MHA. These are all elite forces, where every man is a volunteer, highly trained and motivated. This force is among the most battle hardened and combat rich force equal to if not better than the best in the world. The SOF are both force multiplier and substituter. These forces provide the theatre commanders with a low cost option to target high value military objectives in depth areas, thus giving the much needed strategic and operational reach and flexibility during war.

A major weakness is the lack of a lean and mean, agile and versatile force under a single commander and understanding of the capabilities at the Apex level, though this seems to have changed after the surgical strikes. This can be achieved by reorganising part of the SOF under the Special Operations command (SOC). The SOC should be structured and organised as a truly integrated tri-service command under the CDS with integral lift capabilities. The roles assigned to the SOC in pursuance of the national security objectives would be power projection and intervention to safeguard our national interests and assets in the region. Assistance to friendly Foreign Countries (FFC), albeit on invitation and augment the war effort. A suggested organogram could be.

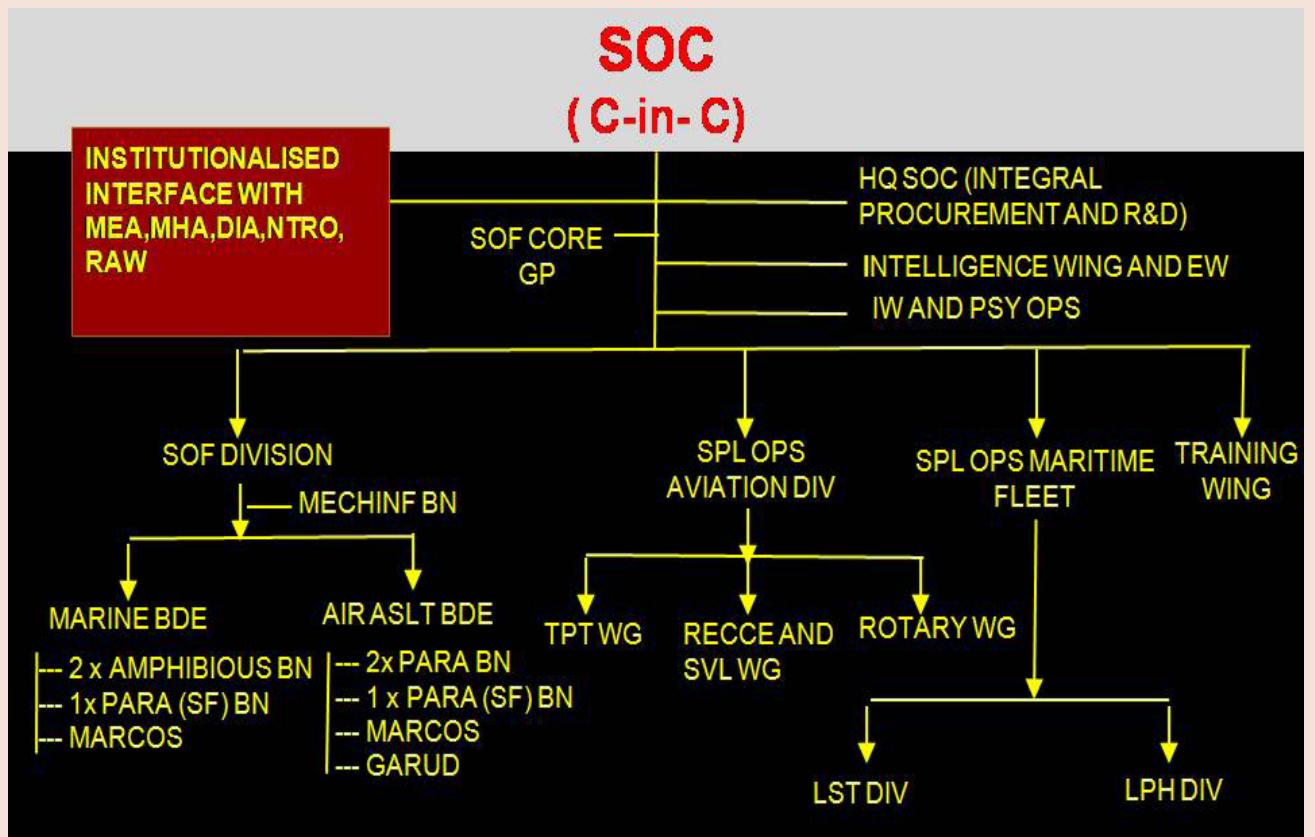

The Air Force has enhanced its lift capability with the induction of the C-130J Hercules and C-17 Globe Master in addition to the in service IL-76 and AN-32 Aircrafts, thus giving the country the requisite reach to effectively intervene and safeguard our national interests in the regional and global context. The Indian Navy too, is in the process of acquiring four landing craft/multi role support vessels at a cost of 2.6 Billion USD and nine Japanese ShinMaywa US2 amphibious aircraft, to upgrade the maritime lift capability for SOF and Amphibious operations. To fully exploit this credible lift capability, the strategic reach of SOF there is an urgent need to have integrated structures to effectively safeguard our national interests as mandated.

There is also a need to clearly define the constituents of SOF and the overarching philosophy that should guide their employment. While special operations are carried out from the tactical to the strategic level, in the context of this paper SOF must constitute only those forces that are specially trained, equipped and organized for conduct of special operations at the operational and strategic level. That implies that such operations must impact and be conducted at the theatre level and beyond. The size of the force is of little consequence and must be appropriate to their tasking. India's geopolitical, geoeconomic and geostrategic interests and aspirations dictate that it build credible capabilities and capacities to protect and project the national interests. Among the

world's major democracies India faces the most complex threats and security challenges spanning the full spectrum of conflict from small wars to collusive and hybrid wars to conventional and nuclear wars. India faces adversarial relations with a mischievous Pakistan which continues to wage a constant and continuous proxy war in J&K, and an emerging world power and aggressive China with whom we share a 3488 km long disputed borders. The internal security situation remains a major challenge as the terrorist now have access to state of the art small arms , weapon systems and explosives, at times even more advanced than those being issued to the security forces. The SOF are not only highly trained and motivated but also the most cost effective, and hence play a critical role in ensuring national security. In keeping with the future and emerging security challenges. The national security structures and the SOF should prepare to counter threats in the multidomain warfare, linear wars are now only a subset of multidomain wars. The SOF are not only agile but also most suited to adapt to future security challenges. The role of the SOF to meet and mitigate these threats that undermine India's strategic interests needs to be defined. These are:-

During war

- Secure/destroy high value targets in strategic and operational depth in furtherance of national military objectives.
- Strategic and operational level

direct action, reconnaissance and surveillance tasks .

- Creating strategic and operational dilemmas at the highest decision making levels of the enemy.

During peace, or rather no war no peace

- The SOF will be the first responder to any emerging or impending threat to our national interest and assets in the region.
- Punitive and pre-emptive operations akin to the surgical strikes in keeping with the revised Counter Terrorism strategy.
- Hostage rescue and evacuation of Indian nationals and diplomats.
- Reinforcement or assist in evacuation of United Nations Peacekeeping Missions.
- Assist Friendly Foreign Countries(FFC) from threats by inimical elements from within, albeit on invitation.
- Assist in HADR missions in the region and beyond .
- Capacity building of Armed Forces and SOF of FFC.
- Securing India's Sea Lines of Communication (SLOC) in concert with Naval Power.
- Ensuring the safety and security of Indian diplomats and citizens abroad in a crisis situation.

The SF much like the armed forces are poorly equipped with critical deficiencies in firepower, communications, surveillance, insertion capabilities and mobility. The SOF requirement is of low population, high technology arms and equipment. The procurement procedures for SOF are the same as for all other arms and equipment as per the DPP. This has obviously resulted in near zero procurements. Indigenous development of high technology equipment is not attractive enough for DRDO and OFB due to the limited quantities required. In any case the inordinate delays in development by DRDO, leave the services with little option other than imports. It has been over two decades since the Army has been trying to procure essential arms and equipment for the SOF, like combat freefall parachutes, small arms, sniper rifles, light strike vehicles, underwater diving equipment, communication equipment, laser target designators, heavy drop equipment and ATGMs. These still remain in various stages of procurement or development. Even low technology equipment like Parachute Jump Boots and Airborne Helmets being indigenously developed continue to be in the development and trial stages for over two decades . The criticality has been compounded with the raising of additional Parachute and Parachute (SF) units. The envisaged procurements have not kept pace, leading to the existing inventory being rationalised, in effect the poverty has been shared.

After marking time for a decade under the previous regime, the MoD woke up from

slumber under Raksha Mantri Mr Manohar Parrikar, signing 110 defence contracts worth 1,13,995 crores and according 'Acceptance of Necessity" (AON) for another 101 schemes valued at 2,39,000 crores. These are all big ticket projects essential to capability development of the armed forces. However , the urgent and critical need of a SF soldier to be equipped with even an effective assault rifle remains unaddressed. The SOF should be provided the requisite wherewithal to fight effectively ensuring protection and survival of soldiers across the complete spectrum of conflict from small and hybrid wars in the sub conventional domain to conventional and nuclear wars. The SOF lack even insertion equipment like combat freefall (CFF) Parachutes, Light Strike Vehicles (LSVs), and underwater combat diving equipment. After the September 28/29, surgical strikes, the defence Ministry has given a go ahead to the three services with a purse of Rs2,000 crore to procure essential equipment and weapon systems. However , this is not the first time that such knee jerk reactions have occurred, the story was rather similar after the 09 June surgical strikes against the NSCN(K) in Myanmar, as also on earlier occasions like OPs PAWAN, CACTUS and VIJAY.

The PARA and PARA SF alone have immediate and urgent plans to procure around 1100 combat freefall parachutes, 11000 fully loaded (with all sights) state of the art lightweight assault rifles , 300 sniper rifles, 72 lightweight rocket launchers, 12 bore shotguns and pistols,

3rd generation ATGMs, automatic General Purpose Machine Guns, Night Vision Devices, Laser target designators, Communication equipment, survival and protection gear, special mountaineering and climbing equipment, among others . The Lack of GPMGs was recognised during the surgical strikes in Myanmar and PoK. for many years now the SF are using the Russian origin Pika Machine Guns captured from foreign terrorists in J&K. It is difficult to comprehend as to how the MHA succeeds in procuring state of the art weapons for the CAPF, where in the MOD succeeds only in delaying all procurements, even of similar weapons which are in service with the CAPF. It is hoped that this will get corrected by the impetus to modernisation and priority in making up critical voids accorded by the Prime Minister and Defence Minister after the surgical strikes .

It is also reported that the Defence Ministry has asked the Army to process the procurement of the equipment for the SF under the fast-track procedure under the DPP 2016. Similar efforts earlier have failed as in effect the fast track procedure actually takes much longer than the normal procurement process and is more prone to failure or foreclosure. The more pragmatic way of meeting the urgent and immediate needs of the PARA & PARA SF would be to constitute empowered committees(EC) to procure the requisite equipment. This proposal was mooted by me as the DG Infantry in 2012, though agreed upon in principle it was never implemented for reasons best known to

the MoD. The procedure exists and has been successfully implemented in case of the EC on Siachen equipment and clothing.

The Special Forces Training school (SFTS) located at Nahan (HP) is a centre of excellence. The training conducted at SFTW is by far one of the best and most meaningful. The SFTS also has trained the SF of foreign friendly countries, there is a constant pressure to enhance the scope and strength of trainees. The SFTS was raised in 1995/1996 when the Indian army had only three Para SF units and five Para units. Today the Para SF units have multiplied and the SFTW is required to train all SF including MARCOS and Garud. There is an imperative to provide a permanent home to SFTS and build the requisite infrastructure. The proposal to move SFTS to Chakarbhata (Chhattisgarh) is flawed and will kill the institution as the training will be restricted to the boundaries of the school, on account of the security situation prevalent and the possibility and proximity to LWE areas, there will be a constant threat to the trainees. In addition the security threat

does not permit training of SF of foreign friendly countries to be conducted at Chakarbhata. The Shekatkar committee has recommended closure of Military farms which has been implemented by the government. The land vacated by one of the military forms could be used for relocating the SFTS. The SFTS has to be provided the infrastructure and wherewithal to enhance the operational efficacy of the SOF by ensuring very high standards of training.

SOF are not only more effective and exciting, but also more efficient and decisive and have delivered in all wars and CI/CT operations. Now that the full potential of the SF has been recognised at the highest levels of the government, it is an imperative to review and implement structural changes and ensure that the requisite wherewithal is provided immediately and procedures are in place for constantly and continuously upgrade the weapons and equipment. To raise the costs for Pakistan the SOF should be prepared for more strikes. As the saying goes the battle has been won the war continues.



Lt Gen Vinod Bhatia, PVSM, AVSM, SM (Retd)

(Former DGMO) Director CENJOWS
Views Expressed are that of the author.

A similar article was first published in Sep 2017 issue of FORCE magazine.

Centre for Joint Warfare Studies

Kashmir House, Rajaji Marg, New Delhi-110 001

Tel. Nos : 011-23792446, 23006535, 23006538/9, Fax : 011-23792444

Website : <http://cenjows.gov.in>, e-mail : cenjows@yahoo.com